

Checking For Condensation Formation on The Inner Surface of The External Walls of Frame Buildings Made of Thermal Blocks

Makhmudov M.M*, Khaitov M.B

Samarkand State Architectural and Construction University named after Mirzo Ulugbek

DOI:

<https://doi.org/10.47134/scbmej.v2i3.4193>

*Correspondence: Makhmudov M.M

Email: xaitov.maruf@samdaqu.edu.uz

Received: 14-05-2025

Accepted: 22-06-2025

Published: 12-07-2025



Copyright: © 2025 by the authors. Submitted for open access publication under the terms and conditions of the Creative Commons Attribution (CC BY) license (<http://creativecommons.org/licenses/by/4.0/>).

Abstract: This study investigates the use of T-shaped thermal blocks composed of fine-grained concrete and basalt slabs to enhance the energy efficiency of frame buildings. Although frame structures are widely used in modern construction for their economic and structural advantages, improving the thermal performance of their external walls remains a critical challenge. This research addresses the knowledge gap by analyzing the structural composition, thermal resistance, and condensation prevention properties of multilayer thermal blocks. A combination of experimental assessment and numerical heat transfer modeling was conducted under the climatic conditions of Samarkand using SmartCalc ThermoCalc. The results demonstrate that the use of basalt insulation and thin adhesive joints significantly reduces thermal bridges and enhances heat retention. The calculated heat transfer resistance of the wall sections exceeded the required norm ($R_o \geq 2.2 \text{ m}^2 \cdot \text{C}/\text{W}$), and simulations showed no condensation on the inner surface even at -15°C , ensuring indoor comfort. These findings imply that T-shaped thermal blocks are an effective, locally sourced solution for sustainable and thermally resilient construction. This has practical implications for reducing energy consumption, operational costs, and environmental impact in cold climates.

Keywords: Energy Efficiency, Thermal Block, Frame Building, Heat Transfer Resistance, Basalt Insulation, Condensation, Thermal Bridge

Introduction

Modern trends in construction dictate the necessity of using materials that simultaneously provide high strength, energy efficiency and environmental safety. One such innovative solution could be T-shaped thermal blocks made from fine-grained concrete and basalt slabs. Thanks to their unique design and materials, thermal blocks represent a promising solution for the construction of energy-efficient buildings with high thermal protection qualities.

T-shaped thermal blocks are highly functional, allowing for the creation of durable enclosing structures with improved thermal insulation properties. The basalt component in their composition serves as an effective thermal insulator, reducing heat losses, while the fine-grained concrete ensures the necessary rigidity and resistance to loads. This combination makes these blocks a practical material for use as wall fillings in the

construction of multi-story and high-rise frame residential and other buildings, meeting modern thermal protection requirements.

The article examines the structural features of T-shaped thermal blocks, their composition, advantages and areas of application. Particular attention is paid to their contribution to increasing the resistance of infill wall structures to external influences and reducing energy consumption costs.

Under the conditions of global growth in energy resource prices and tightening environmental standards, improving the energy efficiency of buildings is becoming one of the key objectives of modern construction. Frame buildings, due to their versatility and cost-effectiveness, are widely used in residential and commercial construction. However, their energy efficiency largely depends on the characteristics of external enclosing structures, such as walls and facades.

The use of thermal blocks based on fine-grained concrete and basalt slabs opens up new opportunities for creating structures with improved thermal insulation properties. Such materials make it possible to reduce heat losses, ensure a comfortable indoor microclimate and significantly reduce heating and air conditioning costs.

Improving energy efficiency also contributes to the reduction of carbon dioxide and other harmful emissions into the atmosphere, which is relevant in the context of the global fight against climate change. The topic becomes particularly important not only for Uzbekistan, but also for many countries where energy saving is an important requirement during the construction and operation of heated buildings.

Literature Review

In recent years, the issue of enhancing the energy efficiency and thermal performance of building envelope structures has gained significant attention in construction science. Numerous researchers have investigated various materials and technologies aimed at improving the thermal insulation properties of external walls, particularly in the context of residential buildings.

Makhmudov and Rustamova conducted an experimental study to assess the uniformity of the thermal conductivity coefficients of brick and plaster materials used in experimental wall fragments. Their research highlighted the importance of precise material selection and uniformity control in the construction of energy-efficient walls. In a related study, Makhmudov, Rustamova, and Nosirova established empirical dependencies between the sorption humidity of keramzite concrete and the relative air humidity, providing valuable insights for optimizing wall material performance in varying climatic conditions.

The innovative application of aerated concrete blocks in residential construction was explored by Shukurov et al. Their work introduced effective solutions for incorporating lightweight concrete blocks to improve thermal efficiency and reduce overall structural loads. Similarly, Bolikulovich analyzed the thermal conditions at the junctions of window frames and walls, underlining the necessity of careful detailing in thermal bridge reduction.

Khaitov provided a comprehensive overview of modern thermal insulation materials, discussing their advantages, production methods, and potential applications in sustainable construction. Complementary to this, a 2024 study utilized the finite difference method for calculating temperature fields in external enclosing structures, demonstrating the effectiveness of numerical methods in thermal performance analysis.

Exploring alternative resources, Mamadaliyev et al. evaluated the prospects of using coal ash in construction, identifying it as a sustainable and thermally efficient material option for building components. Furthermore, Bolikulovich and Rustamova proposed a methodology for the calculation of temperature fields within external building structures, contributing to the development of accurate heat transfer prediction models.

Energy-efficient design strategies were also addressed by Turakulovna and Pulatovich, who focused on improving the thermal performance of external walls in newly built residential projects. Their research emphasized model-based design optimizations to enhance overall building energy efficiency. Additionally, Pulatovich investigated the physical and thermal properties of energy-saving building materials for external walls, offering practical recommendations for selecting appropriate materials based on their heat-insulating capabilities.

Collectively, these studies provide a strong scientific foundation for advancing energy-efficient technologies in building envelope design. They underline the importance of material selection, innovative design approaches, and precise thermal performance calculations in achieving sustainable and high-performance construction solutions.

Enclosing structures play a key role in ensuring the energy efficiency of buildings. In frame buildings, where load-bearing functions are performed by a reinforced concrete frame, external walls mainly serve for thermal insulation and protection against external influences. The quality and characteristics of these structures directly affect the level of heat loss and, consequently, the energy costs for heating and cooling premises.

The thermal blocks we propose are a multilayer wall material (Fig. 1), consisting of an outer shell of durable fine-grained concrete and a thermal insulation layer made of low thermal conductivity materials, such as expanded polystyrene, polyurethane foam, or basalt wool.

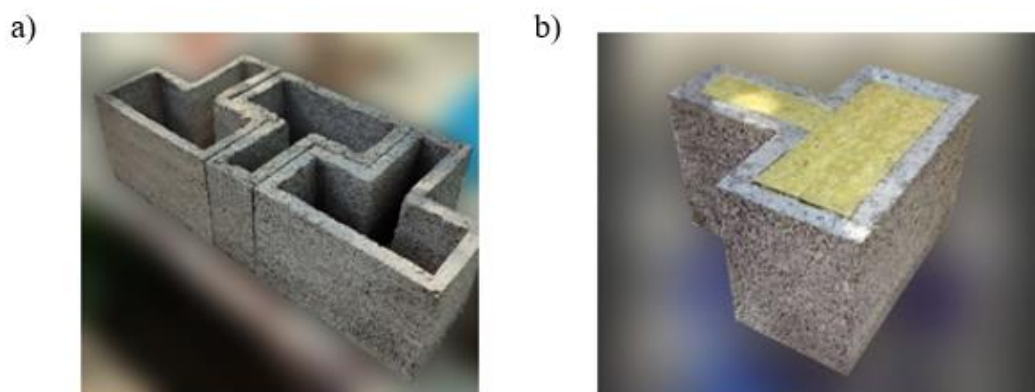

Figure 1. View of a T-shaped thermal block: a – thermal block shell made of fine-grained concrete; b – thermal block with basalt slab insulation.

The use of T-shaped thermal blocks allows:

- Reducing the number of "thermal bridges" in the external wall;
- Decreasing heat losses through walls due to high thermal insulation;
- Reducing heating and air conditioning costs;
- Increasing the durability and resistance of structures to external influences.

The use of innovative thermal insulation materials, such as basalt slabs, makes it possible to improve thermal insulation characteristics while maintaining strength. The production of basalt slabs in Uzbekistan, used as a thermal insulation material, is one of the promising areas for the development of the construction industry and materials science. The presence of local basalt deposits reduces production costs and allows for stable raw material supplies. The introduction of innovative methods for melting and forming basalt fibers contributes to the production of high-quality products that meet international standards. Basalt fiber is an environmentally friendly material, which meets modern requirements of the construction industry.

Methodology

To assess the thermal performance and condensation resistance of T-shaped thermal blocks used in frame buildings, the research employed a combined approach of experimental observation and computational modeling. The structural composition of the thermal blocks—consisting of fine-grained concrete shells and basalt slab insulation—was first examined to determine the relevant physical parameters, including density, thickness, and thermal conductivity. Then, heat engineering calculations were conducted in accordance with national building standards (ShNQ 2.01.01-22 and ShNQ 2.01.04-18), focusing on evaluating the total heat transfer resistance across different wall sections. The SmartCalc ThermoCalc software was used to simulate temperature distributions along four typical wall profiles, with each section comprising multilayer materials varying in composition and thickness. Input parameters included a design outdoor temperature of -15°C , indoor temperature of $+20^{\circ}\text{C}$, average heating period duration of 153 days, and a dew point calculation based on 55% relative humidity. The model computed the internal temperature gradients and corresponding heat transfer resistance (R_0) values, enabling a precise analysis of heat loss dynamics and condensation risk. Joint configurations were also evaluated for their impact on thermal bridging, emphasizing the use of thin adhesive layers to minimize energy loss. This methodology ensured a comprehensive understanding of the thermal efficiency and condensation behavior of the proposed wall system under real-world climatic conditions, particularly in the context of Samarkand's environment. The results guided the interpretation of the blocks' effectiveness in maintaining indoor comfort and supporting energy-efficient design strategies.

Result and Discussion

Results of Heat Engineering Calculation

Particular attention is paid to the technology of laying thermal blocks with the minimization of joint thickness by using adhesive materials, which prevents the formation of large "thermal bridges" (Fig. 2).

To assess the effectiveness of thermal blocks, experimental studies and numerical modeling of heat transfer through enclosing structures are carried out. The use of computer modeling methods makes it possible to predict heat losses and optimize structural solutions even at the design stage.

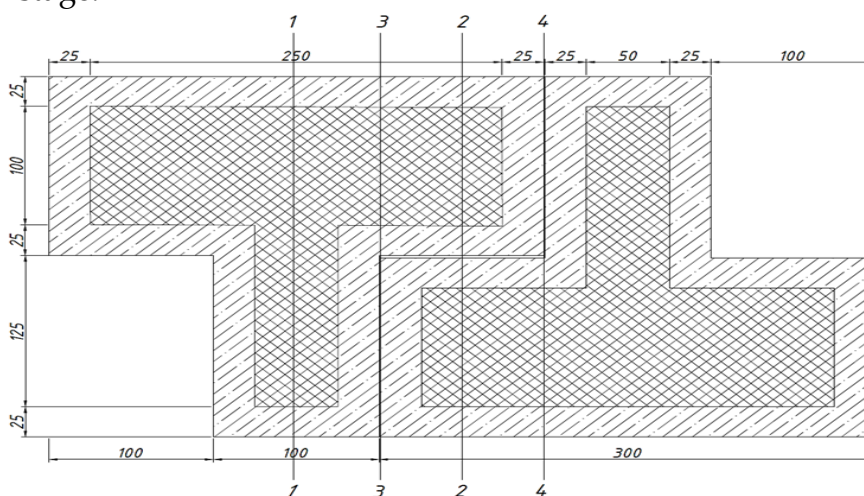

Figure 2. Characteristic sections of an external wall made of T-shaped thermal blocks.

Below are the results of a heat engineering calculation of temperature changes at sections 1-1, 2-2, 3-3, 4-4 of the wall for the climatic conditions of the city of Samarkand, performed using computer modeling from the website www.smartcalc.ru/thermocalc.

Initial data and results of heat engineering calculation for wall section 1-1:

- Design winter outdoor air temperature - $-15\text{ }^{\circ}\text{C}$ [1];
- Design indoor air temperature - $+20\text{ }^{\circ}\text{C}$ [2];
- Duration of the heating period - 153 days [1];
- Average air temperature during the heating period - $4.05\text{ }^{\circ}\text{C}$ [1];
- Operating conditions of the room - A
- Number of degree-days of the heating period (DDHP) - $2440\text{ }^{\circ}\text{C}\cdot\text{days}$ [2];
- Required heat transfer resistance of external walls for the second degree of thermal protection $[R_0^{\text{TP}}]$ - $2.2\text{ (m}^2\cdot^{\circ}\text{C)/W}$ [2].

Table 1. Wall layer materials

Nº	Wall layer materials	Thickness, mm
1	Complex mortar $\gamma_0=1700\text{ kg/m}^3$	10
2	Fine-grained concrete $\gamma_0=1800\text{ kg/m}^3$	25
3	Basalt slab $\gamma_0=120\text{ kg/m}^3$	250
4	Fine-grained concrete $\gamma_0=1800\text{ kg/m}^3$	25
5	Complex mortar $\gamma_0=1700\text{ kg/m}^3$	10

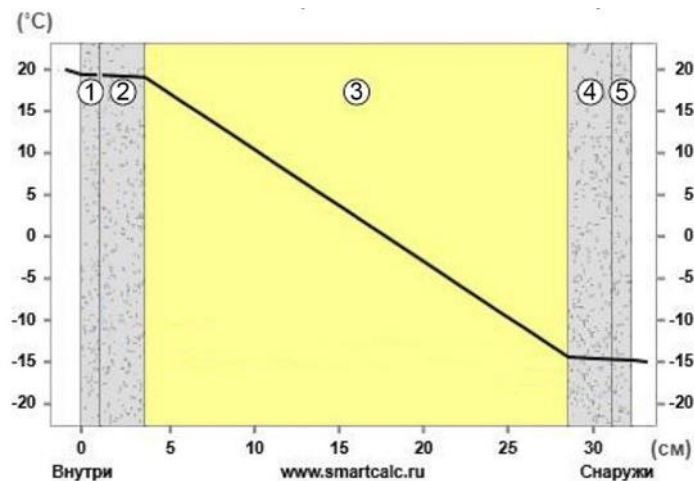

Figure 3. Temperature change graph along section 1-1.

The overall heat transfer resistance of the wall for section 1-1, determined by formula (4) [2], is $R_0 = 6.83 \text{ (m}^2 \cdot \text{°C)/W}$.

A graph of temperature changes along the section 2-2 of the wall is presented in Fig.4.

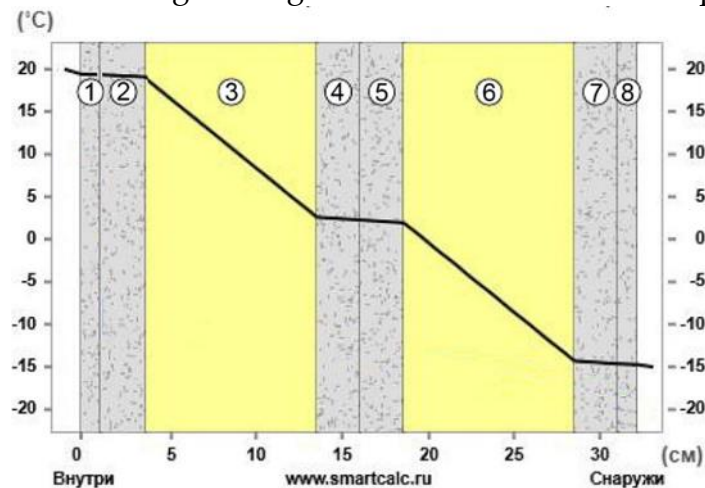

Figure 4. Temperature change graph along section 2-2.

Table 2. Wall layer materials

№	Wall layer materials	Thickness, mm
1	Complex mortar $\gamma_0=1700 \text{ kg/m}^3$	10
2	Fine-grained concrete $\gamma_0=1800 \text{ kg/m}^3$	25
3	Basalt slab $\gamma_0=120 \text{ kg/m}^3$	100
4, 5	Fine-grained concrete $\gamma_0=1800 \text{ kg/m}^3$	25+25
6	Basalt slab $\gamma_0=120 \text{ kg/m}^3$	100
7	Fine-grained concrete $\gamma_0=1800 \text{ kg/m}^3$	25
8	Complex mortar $\gamma_0=1700 \text{ kg/m}^3$	10

The overall heat transfer resistance of the wall for section 2-2, determined by formula (4) [2], is $R_0 = 5,58 \text{ (m}^2 \cdot \text{°C)/W}$.

A graph of temperature changes along the section 3-3 of the wall is presented in Fig.5.

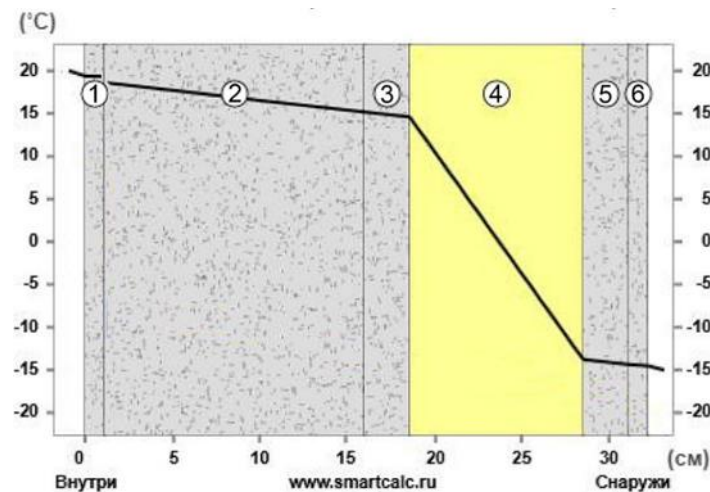

Figure 5. Temperature change graph along section 3-3.

Table 3. Wall layer materials

№	Wall layer materials	Thickness, mm
1	Complex mortar $\gamma_0=1700 \text{ kg/m}^3$	10
2, 3	Fine-grained concrete $\gamma_0=1800 \text{ kg/m}^3$	150+25
4	Basalt slab $\gamma_0=120 \text{ kg/m}^3$	100
5	Fine-grained concrete $\gamma_0=1800 \text{ kg/m}^3$	25
6	Complex mortar $\gamma_0=1700 \text{ kg/m}^3$	10

The overall heat transfer resistance of the wall for section 3-3, determined by formula (4) [2], is $R_0= 3,08 \text{ (m}^2 \cdot \text{°C)/W}$.

A graph of temperature changes along the section 4-4 of the wall is presented in Fig.6.

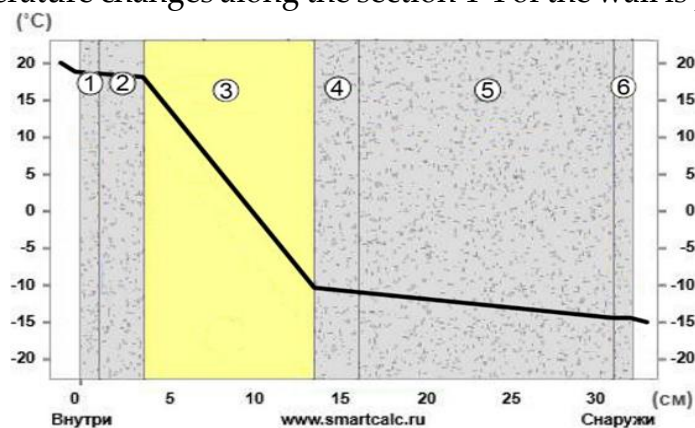

Figure 6. Temperature change graph along section 4-4.

Table 4. Wall layer materials

№	Wall layer materials	Thickness, mm
1	Complex mortar $\gamma_0=1700 \text{ kg/m}^3$	10
2	Fine-grained concrete $\gamma_0=1800 \text{ kg/m}^3$	25
3	Basalt slab $\gamma_0=120 \text{ kg/m}^3$	100
4, 5	Fine-grained concrete $\gamma_0=1800 \text{ kg/m}^3$	175
7	Complex mortar $\gamma_0=1700 \text{ kg/m}^3$	10

The overall heat transfer resistance of the wall for section 4-4, determined by formula (4) [2], is $R_o = 3,08 \text{ (m}^2 \cdot \text{°C)/W}$.

Conclusion

- The total heat transfer resistance of the wall in sections 3-3 and 4-4, where the largest part of the thickness is occupied by fine-grained concrete with a high thermal conductivity coefficient, is $RO = 3.08 \text{ (m}^2 \cdot \text{°C)/W}$, significantly greater than the required heat transfer resistance of external walls for the second degree of thermal protection, equal to $2.2 \text{ (m}^2 \cdot \text{°C)/W}$.
- At the calculated indoor air temperature $t_B = +20^\circ\text{C}$ and relative humidity $\varphi_B = 55\%$, the dew point temperature is $t_p = +9.7^\circ\text{C}$.
- The results of the heat engineering calculation of the temperature change in various sections of the wall made of T-shaped thermal blocks show that when the outside air temperature drops to -15°C , the temperature on the inner surface of the wall does not drop to the dew point temperature in any of the sections under consideration. Consequently, it can be guaranteed that in the climatic conditions of Samarkand, when the outside air temperature drops to -15°C , condensation does not form on the inner surface of such a wall.
- Thus, the construction of external walls of frame buildings from T-shaped thermal blocks is an effective solution for increasing their energy efficiency.

References

- Bolikulovich K. M. Study of the Thermal Conditions of Connections of Window Blocks to a Wall. – 2023.
- Bolikulovich, K. M., & Bakhodirovna, R. D. (2023). Methodology for Calculation of the Temperature Field in the External Fencing Structures of Buildings.
- Calculation of the Temperature Field of External Enclosing Structures Using The Finite Difference Method. (2024). Innovative: International Multidisciplinary Journal of Applied Technology (2995-486X), 165-169.
- Gayrat Shukurov, Khaitov Maruf Bolikulovich, Fazilov Farkhod Holiyevich, Kulmirzayev Jaxongir Ilxomiddinovich, M. Alvan Rizki; Innovative solutions for the use of aerated concrete blocks in residential buildings. AIP Conf. Proc. 24 July 2024; 3167 (1): 060013. <https://doi.org/10.1063/5.0221137>
- Gil, A. (2017). CSPonD demonstrative project: Start-up process of a 25 kW prototype. AIP Conference Proceedings, 1850, ISSN 0094-243X, <https://doi.org/10.1063/1.4984477>
- <https://www.stonebldg.com/understanding-the-importance-of-building-enclosures-in-construction/>

- Invidiata, A. (2018). Selecting design strategies using multi-criteria decision making to improve the sustainability of buildings. *Building and Environment*, 139, 58-68, ISSN 0360-1323, <https://doi.org/10.1016/j.buildenv.2018.04.041>
- Khaliq, W. (2022). Performance evaluation for energy efficiency attainment in buildings based on orientation, temperature, and humidity parameters. *Intelligent Buildings International*, 14(5), 606-622, ISSN 1750-8975, <https://doi.org/10.1080/17508975.2021.1873096>
- Khayitov, M. B. (2021). Thermal insulation materials: advantages and production. *ISJ Theoretical & Applied Science*, 01 (93), 375-378.
- Konstantinov, A. (2018). Providing thermal protection when replacing window blocks in historical buildings. *IOP Conference Series: Earth and Environmental Science*, 177(1), ISSN 1755-1307, <https://doi.org/10.1088/1755-1315/177/1/012019>
- Kornilov, T. (2021). Evaluation of the effectiveness of additional thermal insulation of the basement floor of frame-monolithic buildings in extreme operating conditions. *E3S Web of Conferences*, 263, ISSN 2555-0403, <https://doi.org/10.1051/e3sconf/202126304041>
- Kumar, V.G. (2020). A study report on carbon sequestration by using Hempcrete. *Materials Today: Proceedings*, 45, 6369-6371, ISSN 2214-7853, <https://doi.org/10.1016/j.matpr.2020.11.012>
- Makhmudov M., Rustamova D. Uniformity Check of the Thermal Conductivity Coefficient of Brick and Plaster Used in the Manufacture of Fragments of Experimental Walls for Studying Heat Protective Qualities //Journal of Advanced Scientific Research (ISSN: 0976-9595). – 2021. – T. 1. – №. 1
- Makhmudov, M., Rustamova, D. & Nosirova, S. (2021). Empirical dependence of sorption humidity of keramzybeton concrete on relative humidity of air. *European Journal of Research Development and Sustainability (EJRDS)* Available Online at: <https://www.scholarzest.ComVol, 2>
- Mamadaliyev, X. E., Khaitov, M. B. & Fazilov, F.X. (2024). Prospects for the Use of Coal Ash in the Construction Industry. *International Journal of Scientific Trends*, 3(2), 45–48.
- Pulatovich, M. B. (2021). Energy Efficient Building Materials for External Walls of Residential Buildings Physical Properties of Heat. *International Journal of Culture and Modernity*, 9, 1-11.
- Rezvanpour, M. (2023). Generalizable Thermal Performance of Ventilated Block Walls and Energy Implication of Substitution for Wood-Frame Walls in Cold-Climate

Buildings. *Buildings*, 13(7), ISSN 2075-5309,
<https://doi.org/10.3390/buildings13071577>

ShNQ 2.01.01-22. Climatic and physical-geological data for design.

ShNQ 2.01.04-18. Construction heat equipment.

Siddaiah, R. (2020). Virtual Prototyping of MV HV Modular Multilevel Power Converter using evolutionary Optimization based on ? ?. *ECCE 2020 - IEEE Energy Conversion Congress and Exposition*, 3532-3539, <https://doi.org/10.1109/ECCE44975.2020.9235467>

Siddaiah, R. (2021). Virtual Prototyping Process for Assessment of Medium Voltage Grid-Connected Solid State Transformer Implementations. *2021 IEEE Energy Conversion Congress and Exposition, ECCE 2021 - Proceedings*, 1156-1163, <https://doi.org/10.1109/ECCE47101.2021.9595786>

Toma, V.V. (2021). The effects of thermal insulation on the interior noise level during the day. A case study of a 1960 block of flats located in downtown Bucharest. *IOP Conference Series: Earth and Environmental Science*, 664(1), ISSN 1755-1307, <https://doi.org/10.1088/1755-1315/664/1/012097>

Turakulovna, E. M., & Pulatovich, M. B. (2023). Improving the energy efficiency of the external walls of residential buildings being built on the basis of a new model project. *Open Access Repository*, 4(2), 187-193.

Tusnina, V.M. (2024). THERMAL EFFICIENCY OF EXTERNAL WALLS STEEL BUILDINGS WITH BALCONIES. *Light and Engineering*, 32(1), 63-69, ISSN 0236-2945, <https://doi.org/10.33383/2023-073>

Urbikain, M.K. (2020). Energy efficient solutions for retrofitting a residential multi-storey building with vacuum insulation panels and low-E windows in two European climates. *Journal of Cleaner Production*, 269, ISSN 0959-6526, <https://doi.org/10.1016/j.jclepro.2020.121459>

"Manual for designing new energy-saving solutions for building thermal engineering (to KMK 2.01.04-97*)" / JSC "ToshuyjoyLITI" - Tashkent, IVC "AQATM", 2012.